

A Comprehensive Smart Energy Metering and Billing System for Future-Ready Energy Solutions

Alexander Robert Williams¹, Peter Jameson Davis², Philip Kenneth Harris³, Samuel Kevin Matthews⁴ & Andrew Knox⁵

^{1,2,3&4} Associate Professor, Department of Electrical and Electronics Engineering, Brighton Institute of Technology, Brighton, UK

⁵Associate Professor, EEE, BNMIT, India

ABSTRACT

Internet of Things (IoT) is a system with sensors, software, electronics and connectivity that provides better exchange of information between connected devices, operator. [1,2]. It reduces the effort of human by introducing machine to machine interaction. The awareness of energy consumption pattern is necessary due to growing demand for energy in day to day life [3]. The evolution of IOT offers solutions to many complex applications for smart cities. It is the ability of devices, networks and sensors to communicate with each other, with and without any human interaction [4]. In this project, a smart metering and billing system has been proposed that allows the user to monitor his/her energy usage statistics. The proposed model gives a solution to encourage people to know their energy footprint and take required action to reduce it.

Arduino microcontroller is connected to the Google Firebase database. Arduino measures the energy consumption and sends the data to the firebase database. Android Studio is used to develop an Android application in which a dashboard is created. This application facilitates the Smart Metering of the consumed energy which displays the daily consumption of energy to the consumer as well as the utility. This application will help in the maintenance from the utility side using mobile phones and is accessible 24x7 depending on the user's convenience. The statistics can be used to study the energy profile in detail

KEYWORDS: IoT, Energy metering, Arduino, Google Firebase.

1. INTRODUCTION

The issues of reliability and increasing tariff have lead to the need for energy conservation. The need for effective energy management has become important in the light of increase in critical applications. The awareness on energy consumption pattern obtained from real time monitoring gives the consumer a possibility to make more energy saving decisions. As the conventional door-to-door local monitoring is a gargantuan task for the utilities, therefore, monitoring every end user remotely is essential for an efficient system. The use of sensors and IoT for monitoring energy consumption provides a reference for energy management at the demand side.

The usage of IoT technology promotes inter-connection and interoperability, building and creating an intelligent infrastructure, which is an important part of the future smart world. IoT technology is used for remote monitoring system for energy monitoring. The remote monitoring leads to efficient, cost effective measurement and monitoring of data. Flexibility in deployment makes cloud based system suitable for industrial applications. The Android application dashboard management will enhance the user experience. At present, the monitoring system adopted are not automatable. Efficient remote based monitoring system can provide an effective solution. The proposed system will reduce the labor work and human error faced due to the conventional monitoring system. This idea will provide significant economic benefits, both to consumers and suppliers, and lead to a greener energy usage.

2. SYSTEM REQUIREMENT

The following section provides an overview of system specification which is to built a electronics circuitry to measure AC voltage of 230 V and current ranging 0-5 A of connected load, calculation of energy and power consumed, calculation of total amount based on different tariffs and sending it to Cloud and retrieving through android application in real time.

The software and hardware requirements that are needed for efficient working of the proposed system was identified based on the specifications. Under software requirements, Arduino IDE is a free and open-source software platform for coding of Arduino UNO in C language, that aims to establish connection between sensors and Arduino UNO board. Android Studio is a software used to develop the mobile application. Under hardware requirements, interfacing the sensors (Current Sensor, Voltage Sensor Module) and the Node MCU with the Arduino UNO board is described. The development of the code for the sensors must be done properly in order to minimise errors. The final connection of the sensors along with Arduino UNO, with the load, in order to take the readings, is done carefully. The system requirement is shown in fig 1

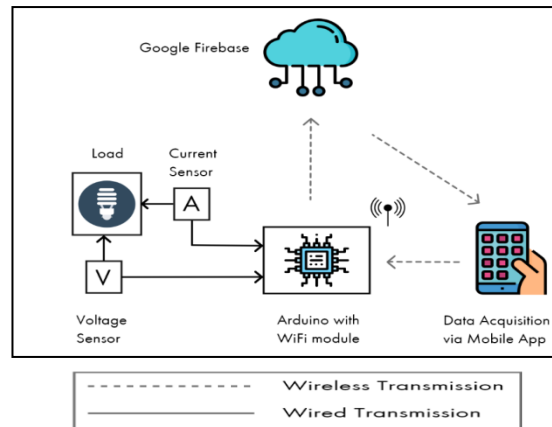

Figure 1: System diagram of Smart Energy Metering and Billing System

3. HARDWARE COMPONENT SELECTION

a. Arduino Uno

It is open source hardware and software platform. Arduino Uno is a microcontroller board based on the ATmega328P. The diagram of Arduino UNO is depicted in figure 2 and its specifications are shown in table 1.

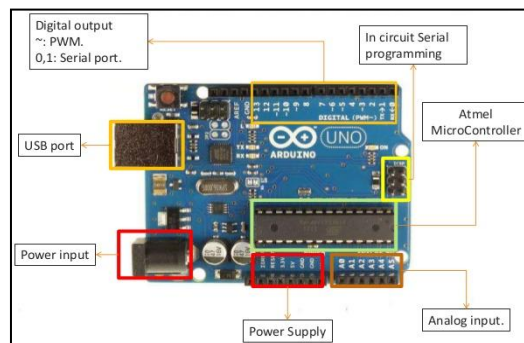

Fig 2. Arduino UNO board

Table 1. Specifications of Arduino Board

Operating Voltage	5V
Input Voltage (recommended)	7-12V
Input Voltage (limits)	6-20V
Digital I/O Pins	14 (of which 6 provide PWM output)
Analog Input Pins	6
DC Current per I/O Pin	40 Ma
DC Current for 3.3V Pin	50mA
Flash Memory	32 KB of which 0.5KB
SRAM	2 KB
EEPROM	1 KB
Clock Speed	16 MHz
Length	68.6 mm
Weight	25g

b. Current sensor ACS 712

It consists of an integrated hall effect sensor which converts current flowing through it into a proportional voltage.

The relation between output voltage of the sensor and sensed current is shown in Figure3. Figure 4 shows the sensor module.

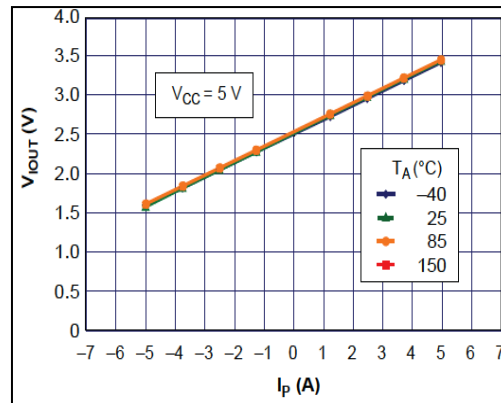

Figure 3 : Output Voltage vs Sensed Current



Figure 4: ACS712 Current Sensor

c. Voltage Sensor Module

It is based on principle of resistive voltage divider design. The voltage divider ratio is 5:1. . The voltage sensor module is shown in figure 5.

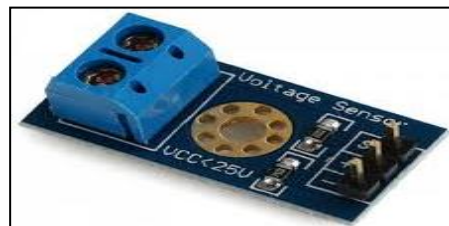

Figure 5: Voltage Sensor Module

d. Node MCU

Node MCU uses ESP8266 which is Wi-Fi enabled system on chip (SoC) module developed by Espressif system. It is mostly used for development of IoT (Internet of Things) embedded applications. Node MCU module is shown in figure 6. Table 2 shows the specifications of ESP8266.

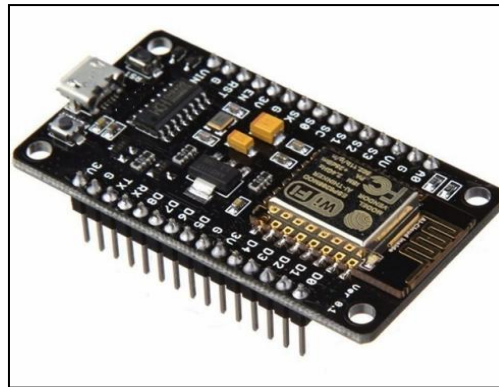

Figure 6: Node MCU - ESP8266

Table 2: ESP8266 Node MCU specifications

Parameters	Specification
Microcontroller	ESP8266
Memory	32 bit
Processor	TenSilica L 106
Processor Clock	80MHz-160MHz
RAM	36Kb
Storage	16 Mb
Built-in WiFi	2.4GHz supports 802.11 b/g/n
ADC Pin	1(10bit Resolution)
GPIO pins	10
Operating Voltage	3.0V 3.6V
Operating Current	80mA(Average)
Operating Temperature Range	-40oC - 125 oC

4. SOFTWARE IMPLEMENTATION

Android Studio is the official integrated development environment (IDE) for Google's Android operating system, built on JetBrains' IntelliJ IDEA software and designed specifically for Android development. It is an open source platform. The various modules used for the software development are sensing data, upload data to Firebase, retrieve data from Firebase to App, Android application development. Figure 7 below show the flowchart for the software module created.

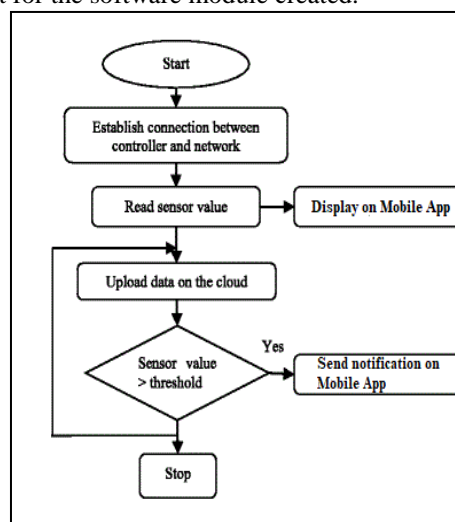

Figure 7: Flowchart for software development

5. RESULTS AND DISCUSSION

The implementation of the hardware circuit is shown in figure 8

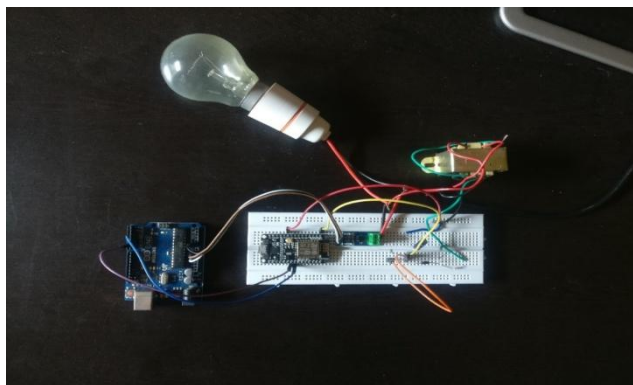

Figure 8: Hardware implementation of the work

Snapshots are shown as results for better understanding of the project and for the end user to visualize various processes. Various snapshots of different app screens show how end user can see the output produced for the developed system.

The current and voltage sensor readings of the Smart Energy Metering and Billing System on google firebase is depicted in the Figure 9 and the dashboard page shown in figure 10, shows the live data readings of the sensors regarding amount, current, voltage, energy, and power. This dashboard also indicates the tariff which is charged based on total Energy consumption.

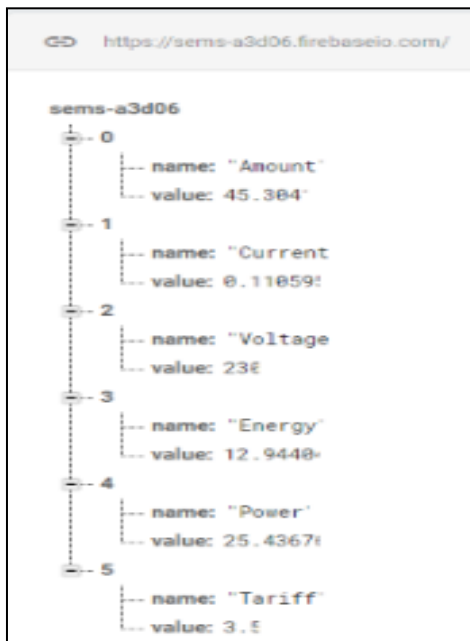

Fig 9. Sensor Reading on Google Firebase

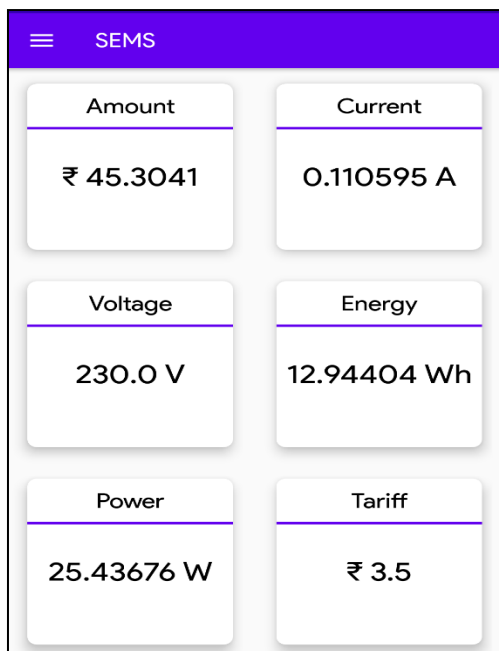

Fig 10 Dashboard

Table 3 shows the hourly reading of various parameters on the app for an incandescent bulb load on 100 W rating. The readings were taken from 8:00 AM to 8:00 PM on an hourly basis. Fig. 11 shows the readings at 5:00 PM on the app’s dashboard.

Table 3: Hourly reading for an Incandescent bulb load

Time	Energy	Tariff plan in Rs.	Amount in Rs.
8:00 AM	0 kWh	3.5/kWh	0.00
9:00 AM	0.115 kWh	3.5/kWh	0.4025
10:00 AM	0.23 kWh	3.5/kWh	0.805
11:00 AM	0.345 kWh	3.5/kWh	1.2075
12:00 PM	0.46 kWh	3.5/kWh	1.61
1:00 PM	0.575 kWh	4/kWh	2.07
2:00 PM	0.69 kWh	4/kWh	2.53
3:00 PM	0.805 kWh	4/kWh	2.99
4:00 PM	0.92 kWh	4/kWh	3.45
5:00 PM	1.035 kWh	4.5/kWh	3.9675
6:00 PM	1.15 kWh	4.5/kWh	4.484
7:00 PM	1.265 kWh	4.5/kWh	5.00
8:00 PM	1.38 kWh	4.5/kWh	5.51

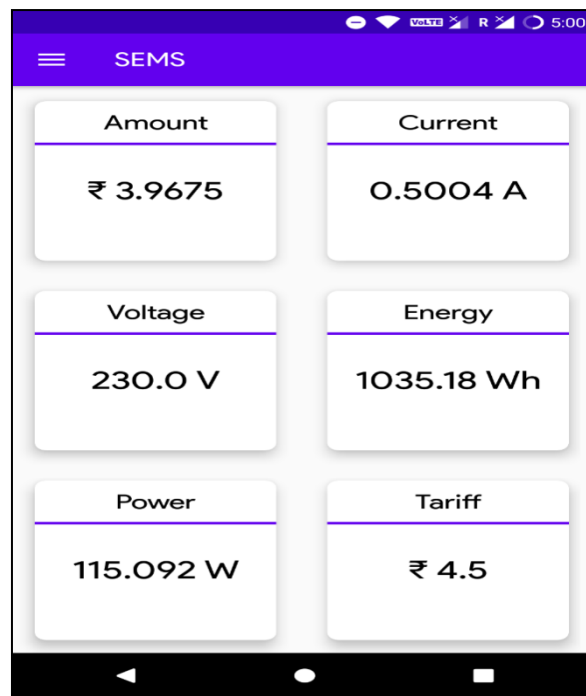

Fig 11: Dashboard Reading at 5:00 PM

6. CONCLUSION

The existing system has some of the problems like manual work, human errors, inaccurate meter reading, corruption, power theft. In the proposed system the electricity connection to each user will be given only to the registered user and the smart billing will be done via IoT (Internet of Things). This system helps in controlling energy consumption and avoiding energy wastage is very important. Smart monitoring of the energy usage can be done by integrating IOT technologies with handy monitoring devices like mobile phones. Different sensors are installed on microcontroller board and are encoded using Arduino IDE to generate proper readings. Arduino IDE is then connected to the firebase for real time data transfer and storage. These data are then received by Android application developed using Android Studio. Once a user opens this application, he/she is presented with a dashboard showing real time sensors reading, energy usage and the total amount based on energy consumed.

REFERENCES

- [1] D. B. Avancini, S. G. B. Martins, R. A. L. Rabelo, P. Solic and J. J. P. C. Rodrigues, "A Flexible IoT Energy Monitoring Solution," 2018 3rd International Conference on Smart and Sustainable Technologies (SpliTech), Split, 2018, pp. 1-6.
- [2] A. S. Pattanayak, B. S. Pattnaik and B. N. Panda, "Implementation of a smart grid system to remotely monitor, control and schedule energy sources using Android based mobile devices," 2014 9th International Conference on Industrial and Information Systems (ICIIS), Gwalior, 2014, pp. 1-5.
- [3] H. Das and L. C. Saikia, "GSM enabled smart energy meter and automation of home appliances," 2015 International Conference on Energy, Power and Environment: Towards Sustainable Growth (ICEPE), Shillong, 2015, pp. 1-5.
- [4] Brown, Eric (13 September 2016). "Who Needs the Internet of Things?". Linux.com. Retrieved 23 October 2016